

REPAIR PARTS MANUAL
MODEL NO. 14592RB (BA14592RBD)
Lawn Tractor

McCULLOCH^{PM}

HOW TO USE THIS MANUAL

This manual is designed to provide the customer with a means to identify the parts on his/her tractor when ordering repair parts. The illustrations may or may not represent the actual assemblies; therefore, it is not recommended to use this manual as a guide to assemble or disassemble the tractor. Some hardware and parts are drawn larger in order to more readily identify them.

Each tractor has its own model number.

The model number for your tractor can be found on the fender under the seat.

When ordering parts, always give the following information:

- Product - "Tractor"
- Model Number - "14592RB (BA14592RBD)"
- Part Number
- Part Description

TABLE OF CONTENTS

SCHEMATIC	3
ELECTRICAL	4-5
CHASSIS	6-7
DRIVE	8-9
STEERING	10-11
SEAT	12
DECALS	13
ENGINE	14-15
MOWER LIFT	16-17
MOWER DECK	18-19
BAGGER	20-21

TRACTOR- -MODEL NO. 14592RB (BA14592RBD), PRODUCT NO. 964 77 25-02
SCHEMATIC

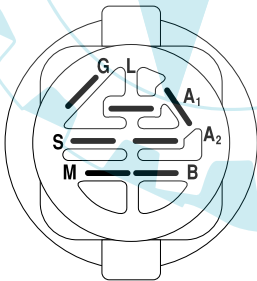
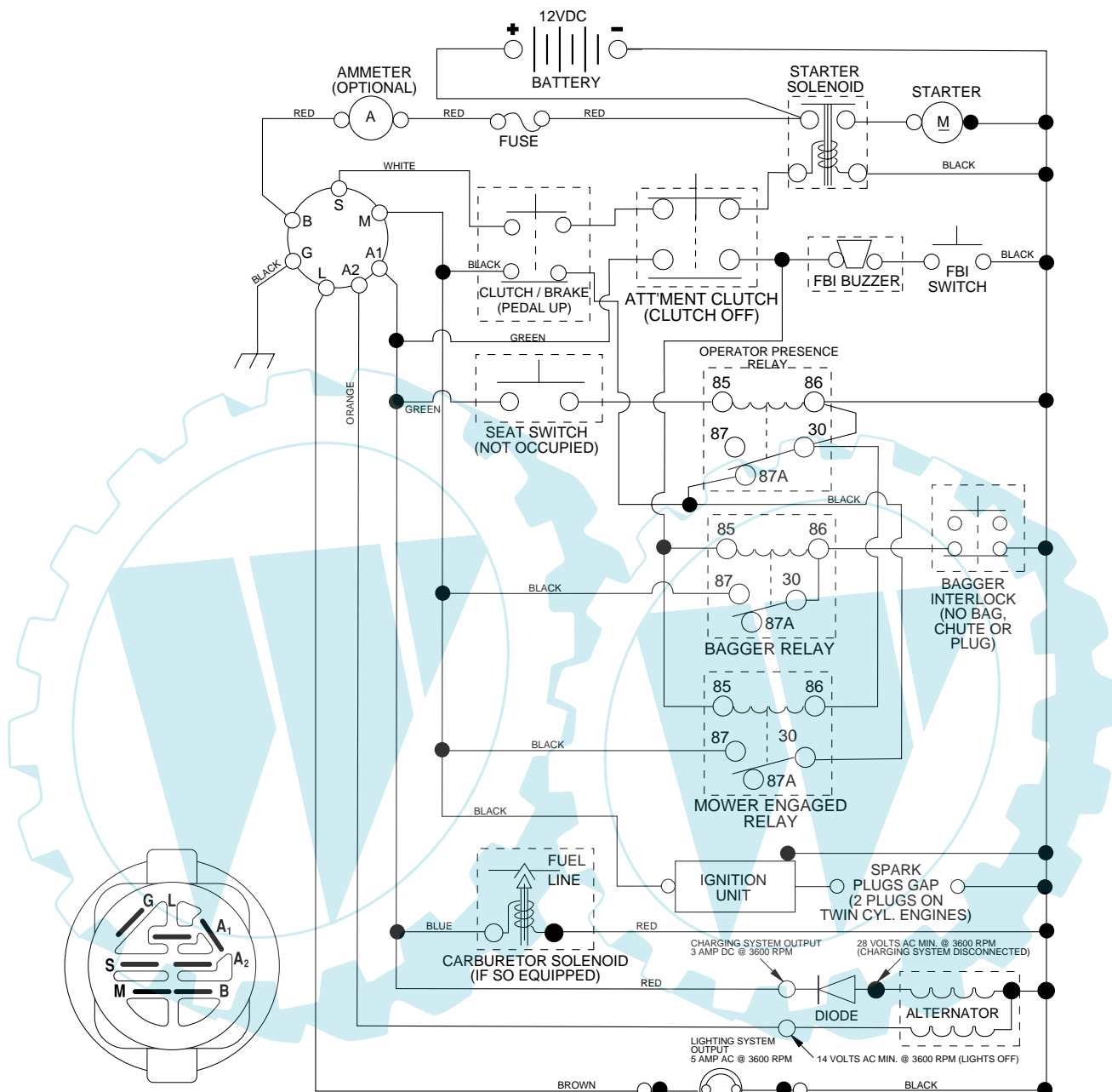

IGNITION SWITCH

POSITION	CIRCUIT	"MAKE"
OFF	M+G+A1	NONE
RUN/LIGHT	B+A1	A2+L
RUN	B+A1	NONE
START	B + S + A1	NONE

WIRING INSULATED CLIPS
NOTE: IF WIRING INSULATED CLIPS WERE REMOVED FOR SERVICING OF UNIT, THEY SHOULD BE REPLACED TO PROPERLY SECURE YOUR WIRING.

●
NON-REMOVABLE CONNECTIONS

○
REMOVABLE CONNECTIONS

PTO SWITCH

POSITION	CIRCUIT
OFF	C + G, B + H
ON	C + F, B + E, A + D

NOTE
 YOUR TRACTOR IS EQUIPPED WITH A SPECIAL ALTERNATOR SYSTEM. THE LIGHTS ARE NOT CONNECTED TO THE BATTERY, BUT HAVE THEIR OWN ELECTRICAL SOURCE. BECAUSE OF THIS, THE BRIGHTNESS OF THE LIGHTS WILL CHANGE WITH ENGINE SPEED. AT IDLE THE LIGHTS WILL DIM. AS THE ENGINE IS SPEEDED UP, THE LIGHTS WILL BECOME THEIR BRIGHTEST.

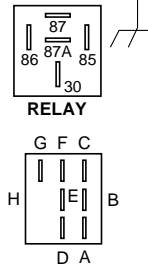

REPAIR PARTS

TRACTOR- -MODEL NO. 14592RB (BA14592RBD), PRODUCT NO. 964 77 25-02
ELECTRICAL

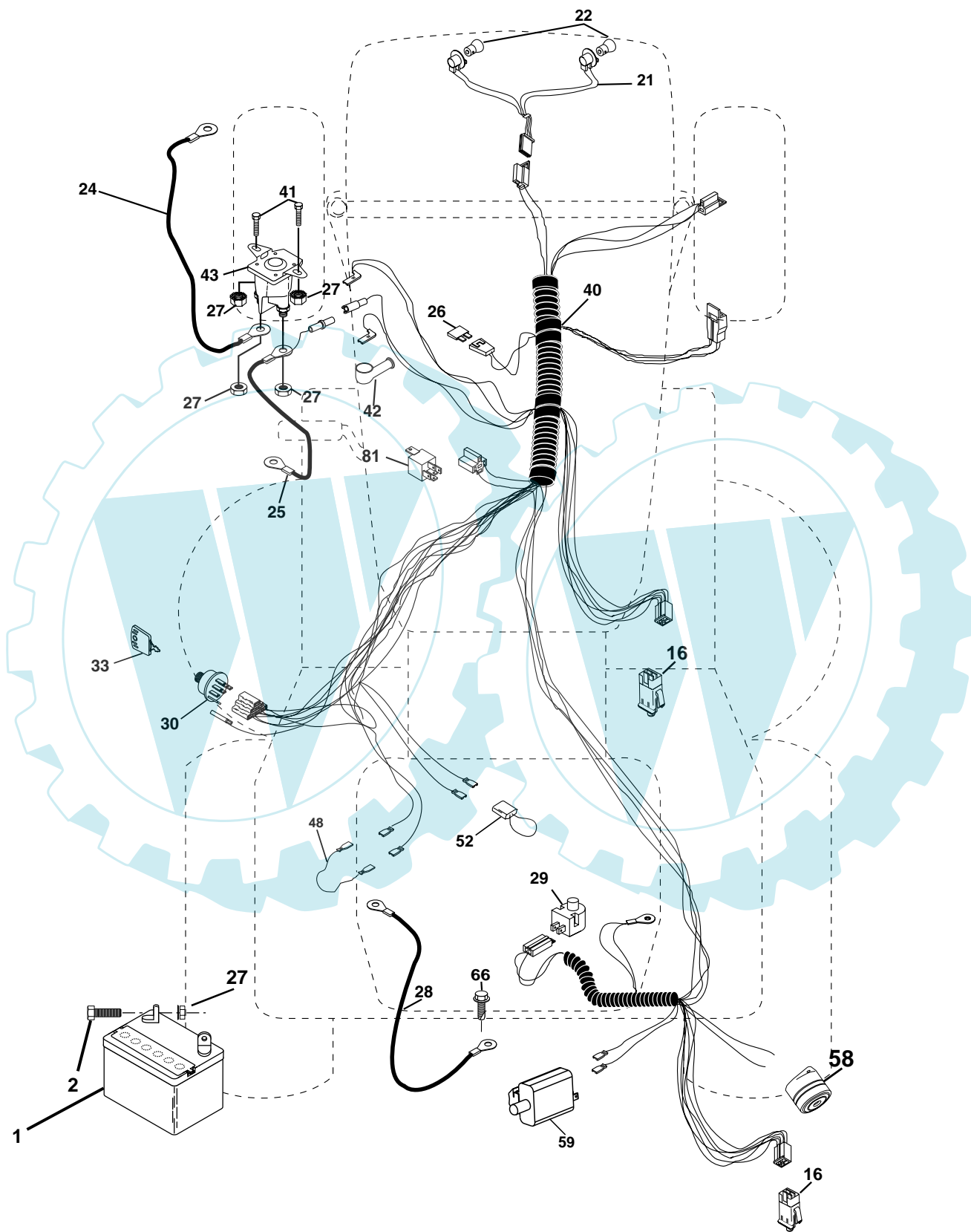

REPAIR PARTS

TRACTOR- -MODEL NO. 14592RB (BA14592RBD), PRODUCT NO. 964 77 25-02
ELECTRICAL

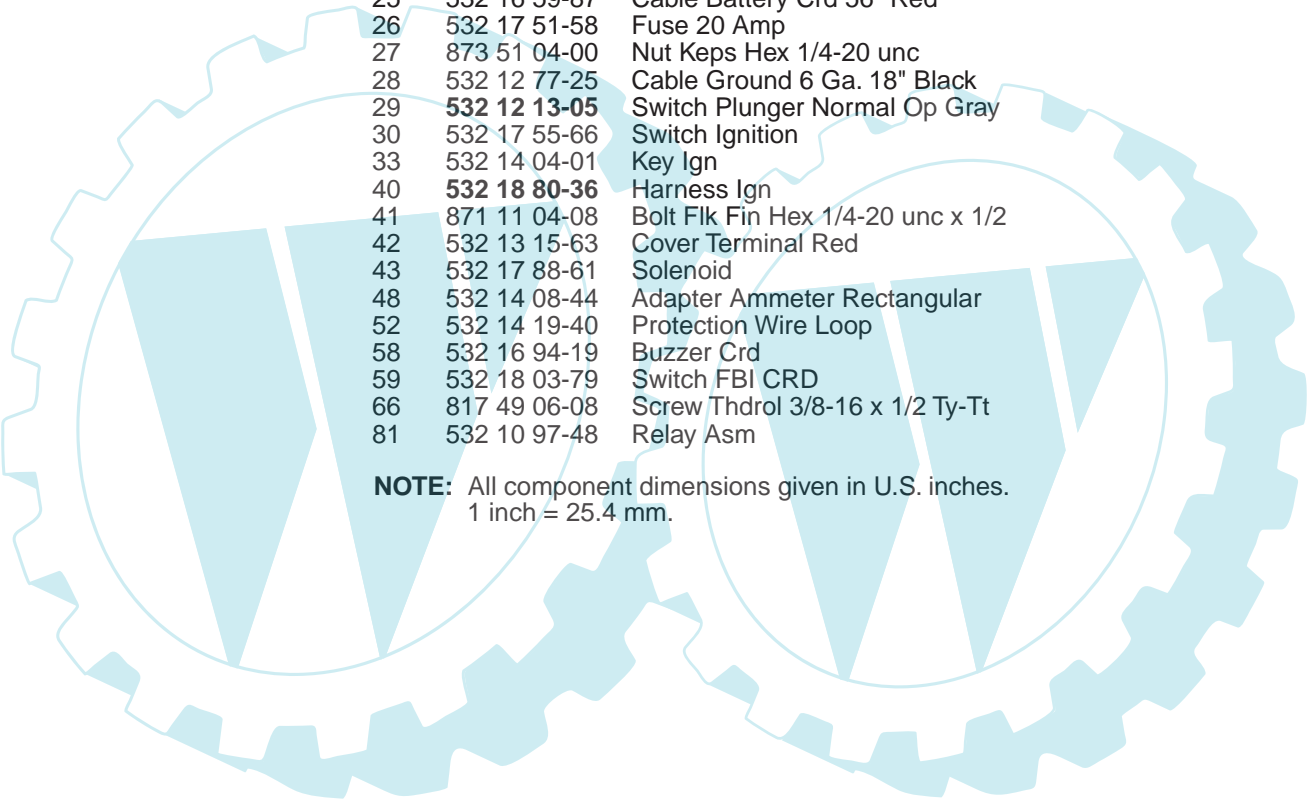

KEY NO.	PART NO.	DESCRIPTION
1	532 16 34-65	Battery
2	874 76 04-12	Bolt Hex Hd 1/4-20 unc x 3/4
16	532 17 61-38	Switch Interlock Push-In
21	532 18 37-59	Harness Asm. Light
22	532 00 41-52	Bulb
24	532 12 47-80	Cable Starter 6 Ga. 11" Red
25	532 16 59-87	Cable Battery Crd 56" Red
26	532 17 51-58	Fuse 20 Amp
27	873 51 04-00	Nut Keps Hex 1/4-20 unc
28	532 12 77-25	Cable Ground 6 Ga. 18" Black
29	532 12 13-05	Switch Plunger Normal Op Gray
30	532 17 55-66	Switch Ignition
33	532 14 04-01	Key Ign
40	532 18 80-36	Harness Ign
41	871 11 04-08	Bolt Flk Fin Hex 1/4-20 unc x 1/2
42	532 13 15-63	Cover Terminal Red
43	532 17 88-61	Solenoid
48	532 14 08-44	Adapter Ammeter Rectangular
52	532 14 19-40	Protection Wire Loop
58	532 16 94-19	Buzzer Crd
59	532 18 03-79	Switch FBI CRD
66	817 49 06-08	Screw Thdrol 3/8-16 x 1/2 Ty-Tt
81	532 10 97-48	Relay Asm

NOTE: All component dimensions given in U.S. inches.
1 inch = 25.4 mm.

REPAIR PARTS

TRACTOR- -MODEL NO. 14592RB (BA14592RBD), PRODUCT NO. 964 77 25-02
CHASSIS AND ENCLOSURES

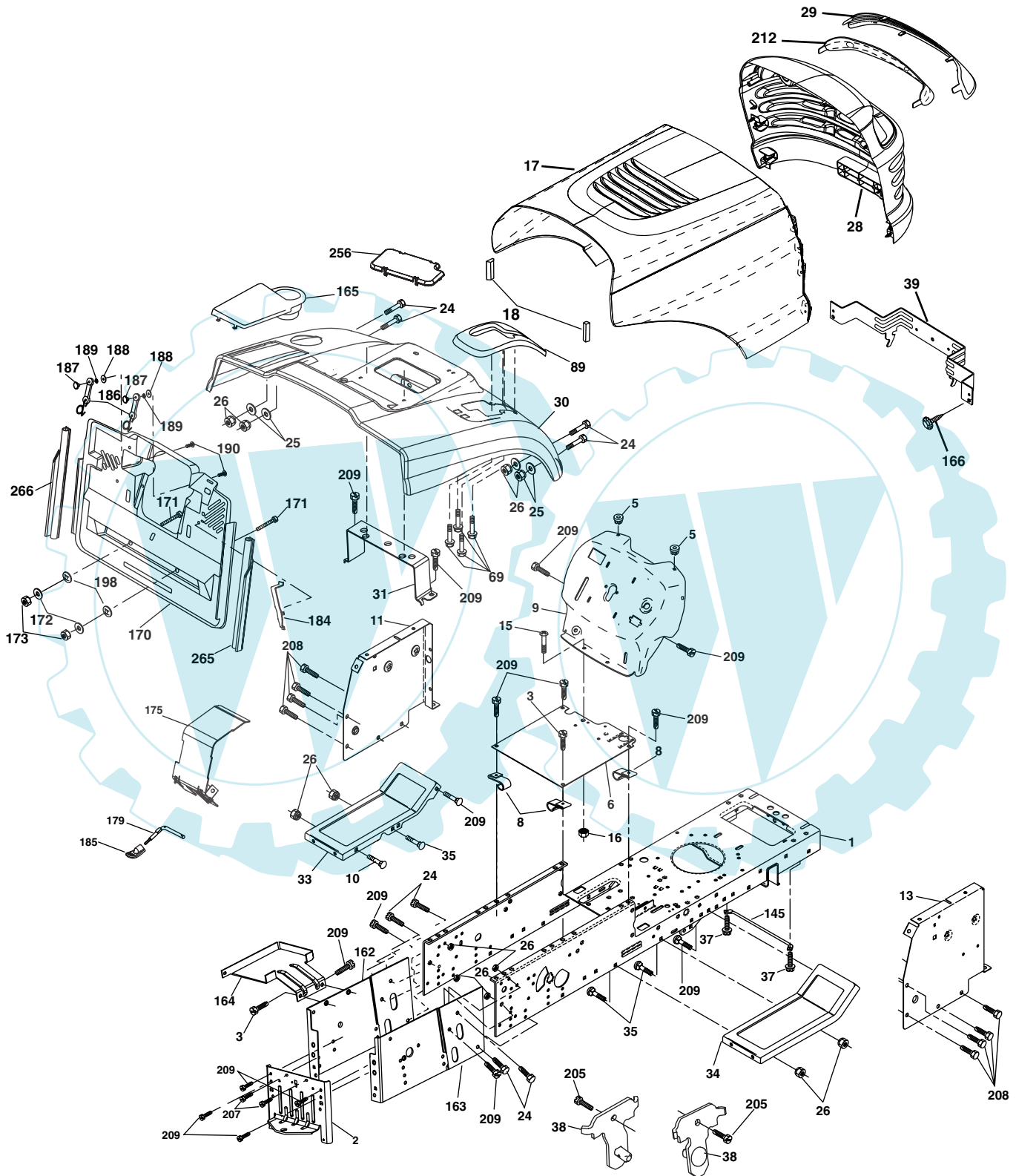

chassis_Elite Value_CRD_4

REPAIR PARTS

TRACTOR- -MODEL NO. 14592RB (BA14592RBD), PRODUCT NO. 964 77 25-02
CHASSIS AND ENCLOSURES

KEY NO.	PART NO.	DESCRIPTION	KEY NO.	PART NO.	DESCRIPTION
1	532 17 46-20	Chassis	89	532 18 13-88	Console
2	532 18 03-84	Drawbar	145	532 15 65-24	Rod Pivot Chassis/Hood
3	817 06 06-12	Screw 3/8-16 x .75	162	532 18 03-82	Bracket Exten Chassis Lh CRD
5	532 15 52-72	Bumper Hood/Dash	163	532 18 03-83	Bracket Exten Chassis Rh CRD
6	532 18 44-19	Saddle	164	532 16 56-05	Support Battery CRD
8	532 12 64-71	Clip Insulator 13/32 Mtg. Hole	165	532 18 13-56	Cover Battery CRD Lt
9	532 18 54-80	Dash	166	532 17 18-75	Screw HWHD Hi-Lo #13-16 x 3/4
10	872 14 06-08	Bolt, Carriage 3/8-16 x 3/4	170	532 17 88-62	Backplate CRD
11	532 17 49-96	Panel, Dash, L.H.	171	872 14 06-20	Bolt Rdhd Sqnk 3/8-16 x 2-1/2 Gr. 5
13	532 18 69-52	Panel, Asm. Dash R.H.	172	819 13 20-16	Washer 13/32 x 1-1/4 x 16 Ga.
15	874 18 05-12	Screw, Machine, Truss Head 5/16-18 unc x 3/4	173	873 51 06-00	Nut, Keps Hex 3/8-16 unc
16	873 51 05-00	Nut	175	532 18 82-03	Trap Door CRD
17	532 18 65-80	Hood Assembly	179	532 18 03-76	Rod Pivot FBI CRD
18	532 12 69-38	Bumper Hood	184	532 17 46-62	Bracket Actuator Bagger CRD
24	874 78 06-16	Bolt	185	532 18 11-01	Knob Rod
25	819 13 13-12	Washer 13/32 x 13/16 x 12 Ga.	186	532 16 07-93	Latch Asm Multch Bagger
26	873 80 06-00	Nut	187	532 12 50-04	Nut Weld .327/.304 #10-24
28	532 18 35-52	Grille Lens Asm (Includes Key Nos. 29 and 212)	188	819 06 12-16	Washer #10
29	532 18 58-46	Lens Grille	189	810 07 10-00	Washer Lock #10
30	532 18 25-06	Fender	190	871 08 10-10	Screw Pan Hd Phillips 10-24 x 5/8
31	532 16 51-56	Bracket, Fender Support	198	532 16 89-37	Nut Push
33	532 18 25-07	Footrest, L.H.	205	817 49 06-08	Screw 3/8-16 x 1/2
34	532 18 25-08	Footrest, R.H.	207	817 67 05-08	Screw 5/16-18 x 1/2
35	872 11 06-06	Bolt	208	817 67 06-08	Screw Thdrol 3/8-16 x 1/2
37	817 49 05-08	Screw Thdrol 5/16-18 x 1/2 TYT	209	817 00 06-12	Screw Hex Wsh Thdrol 3/8-16 x 3/4
38	532 18 17-48	Bracket Asm Pivot Mower Rear	212	532 18 35-50	Insert Lens Reflective
39	532 17 47-14	Bracket Pivot Laser/Elite LT	256	532 18 13-61	Cover Fender Rack CRD
69	532 14 24-32	Screw Hex 1/4-1/2	265	532 18 57-04	Seal RH Side Bagger
			266	532 18 57-03	Seal LH Side Bagger

NOTE: All component dimensions given in U.S. inches.
1 inch = 25.4 mm.

REPAIR PARTS

TRACTOR- -MODEL NO. 14592RB (BA14592RBD), PRODUCT NO. 964 77 25-02
DRIVE

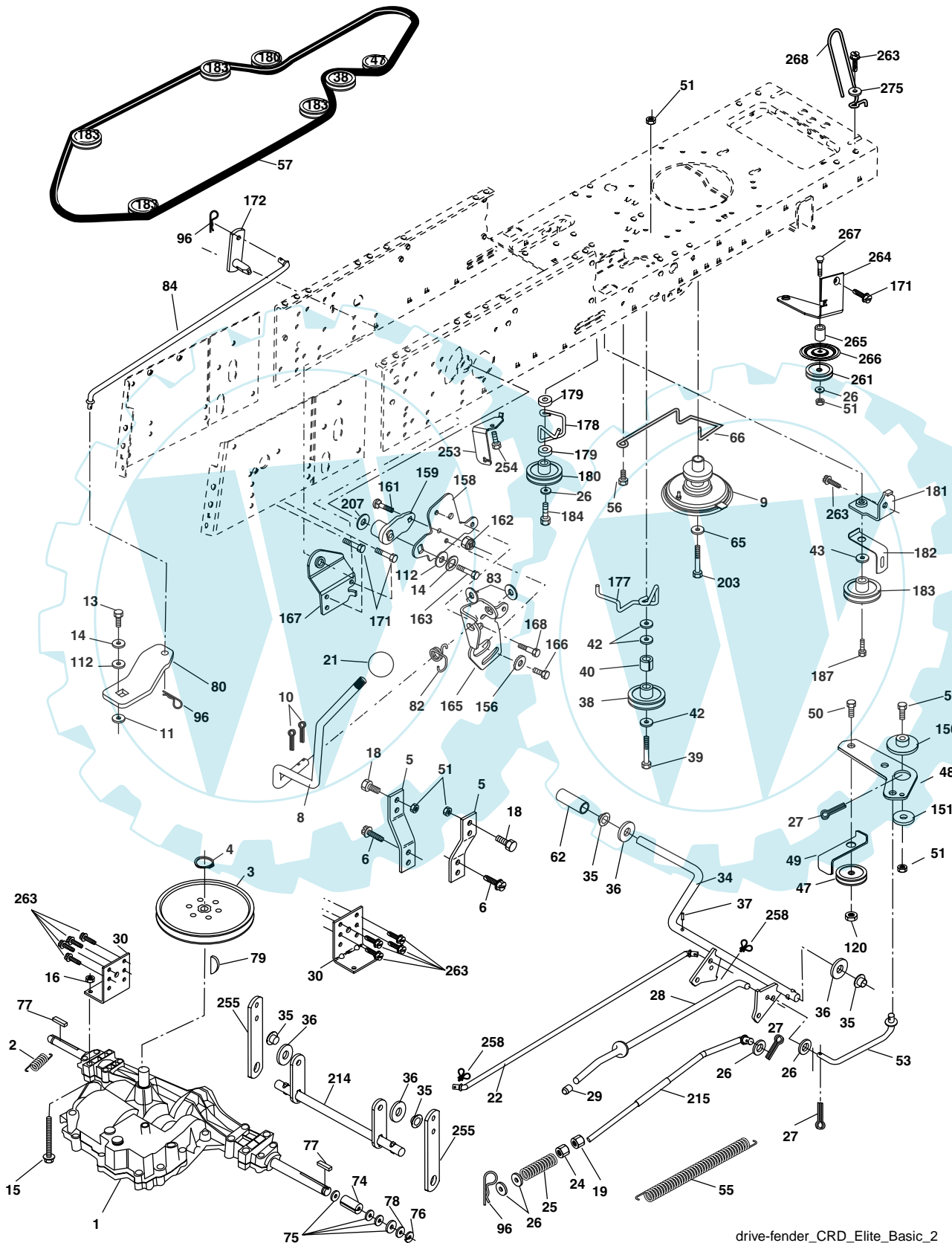

drive-fender_CRD_Elite_Basic_2

REPAIR PARTS

TRACTOR- -MODEL NO. 14592RB (BA14592RBD), PRODUCT NO. 964 77 25-02
DRIVE

KEY NO.	PART NO.	DESCRIPTION	KEY NO.	PART NO.	DESCRIPTION
1	-----	Transaxle Peerless 206-546 Order parts from transaxle manufacturer	78	532 12 17-48	Washer 25/32 x 1-5/8 x 16 Ga.
2	532 14 66-82	Spring Brake Return	79	532 12 50-96	Key Woodruff
3	532 16 59-99	Pulley Transaxle	80	532 14 50-90	Arm Shift PMST 20" Tires
4	812 00 00-28	Ring Retainer #5100-62	82	532 16 57-11	Spring, Torsion
5	532 12 15-20	Strap torque 30 degrees	83	819 17 12-16	Washer 17/32 x 3/4 x 16 Ga.
6	817 06 05-12	Screw 5/16-18 x 3/4	84	532 16 56-21	Link Shift CRD Pmst 18" Tires
8	532 16 56-19	Rod Shift Fender Adjust Lt	96	532 12 47-88	Spring, Retainer 1"
9	532 18 03-54	Clutch Asm Noram	112	819 09 12-10	Washer 9/32 x 3/4 x 10 Ga.
10	876 02 04-16	Pin, Cotter 1/8 x 1	120	873 90 06-00	Nut Lock 3/8-16
11	532 10 57-01	Washer Plate Shf .3888 sq hole	150	532 16 58-50	Bushing, Bellcrank Grnd Dr
13	874 55 04-12	Bolt 1/4-28 unf Gr. 8 w/patch	151	819 13 32-10	Washer 13/32 x 2 x 10 Ga.
14	810 04 04-00	Washer, Lock Hvy Helical	156	532 16 60-02	Washer Srrd 5/16 ID x 1.125
15	874 49 05-40	Bolt Hex FGHD 5/16-18 x Gr. 5	158	532 16 55-89	Bracket Shift Mount
16	873 80 05-00	Nut, Lock Hex w/Ins 5/16-18 unc	159	532 18 39-00	Hub Shift
18	874 78 06-16	Bolt Hex 3/8-16 unc x 1 Gr. 5	161	872 14 04-06	Bolt Rdhd Sqnk 1/4-20 x 3/4 Gr. 5
19	873 80 06-00	Nut, Lock Hex w/Wsh 3/8-16 unc	162	873 68 04-00	Nut Crownlock 1/4-20 unc
21	532 10 69-33	Knob Round 1/2-13 unc Blk	163	874 78 04-16	Bolt Hex Fin 1/4-20 unc x 1 Gr. 5
22	532 17 56-07	Rod, Brake CRD Main	165	532 16 56-23	Bracket Pivot Lever
24	873 35 06-00	Nut	166	817 49 05-10	Screw 5/16-18 x 5/8
25	532 10 68-88	Spring, Rod, Brake	167	532 16 55-88	Bracket Support Shift CRD
26	819 13 13-16	Washer 13/32 x 13/16 x 16 Ga.	168	532 16 54-92	Bolt Shoulder 5/16-18 x .561
27	876 02 04-12	Pin, Cotter 1/8 x 3/4	171	817 49 06-08	Screw Thdrol 3/8-16 x 1/2 Ty-Tt
28	532 17 57-65	Rod, Parking Brake	172	532 16 56-35	Shaft Asm Shift Front CRD PMST
29	532 07 16-73	Cap, Parking Brake	177	532 16 59-32	Keeper Flat Idler 3.06" CRD
30	532 17 49-73	Bracket, Mfg. Transaxle	178	532 16 59-33	Keeper Belt Idler 1.88" CRD
34	532 17 55-78	Shaft, Asm Pedal Foot CRD	179	532 12 09-58	Washer Sintered
35	532 12 01-83	Bearing, Nylon	180	532 16 56-30	Pulley Flat Composite 3.06"
36	819 21 16-16	Washer 21/32 x 1 x 16 Ga.	181	532 18 02-11	Bracket Idler Ground Drive CRD
37	532 12 49-63	Pin, Roll 3/16 x 1"	182	532 18 26-82	Keeper Belt 2.5" Od V-Idler CRD
38	532 16 59-36	Pulley, Flat	183	532 18 60-07	Pulley V-Idler 2.50" Od CRD
39	874 76 06-44	Bolt Fin Hex 3/8-16 unc x 2-3/4	184	817 49 06-44	Screw Hexwsh Thdrol 3/8-16 x 2-3/4
40	532 12 49-65	Spacer, Split 395 x 59 Bzp	187	817 58 05-20	Screw 5/16-18 x 1.25
42	819 13 13-12	Washer 13/32 x 13/16 x 12 Ga.	203	871 17 07-80	Bolt Hex 7/16-20 x 5
43	819 11 10-12	Washer 11/32 x 5/8 x 12 Ga.	214	532 17 56-09	Shaft Asm. Brake
47	532 12 77-83	Pulley, Idler, V Groove Plasic	215	532 17 56-51	Rod Brake Secondary
48	532 15 44-07	Bellcrank Clutch Grnd Drv	253	532 17 50-28	Bracket Cable Chassis
49	532 12 32-05	Retainer, Belt Style Spring	254	817 00 06-16	Screw 3/8-16 x 1
50	872 11 06-12	Bolt Carr Sh 3/8-16 x 1-1/2 Gr. 5	255	532 17 56-08	Brace Shaft Brake
51	873 68 06-00	Nut, Crownlock 3/8-16 unc	258	532 17 80-62	Clip Retainer
53	532 10 57-10	Link, Clutch 7.66	261	532 13 14-94	Pulley Idler Flat Plated
55	532 10 57-09	Spring, Return, Clutch	263	817 00 06-12	Screw Hex Wsh THDR 3/8-16 x 3/4
56	817 06 06-20	Screw 3/8-16 x 1-1/4	264	532 18 19-95	Bracket Clutch
57	532 16 56-31	V-Belt Kev PMST CRD	265	532 18 20-13	Spacer Idler Chassis
62	532 12 48-72	Cover, Pedal	266	532 18 20-61	Shield Idler
65	810 04 07-00	Washer	267	872 14 06-26	Bolt Rd Sqk 3/8-16 x 3-1/4
66	532 15 47-78	Keeper, Belt Engine F-Proof	269	532 18 24-02	Guard Muffler OHV B&S RH
74	532 13 70-57	Spacer Axle	275	819 13 16-14	Washer 13/32 x 1 x 14 Ga.
75	532 12 17-49	Washer 25/32 x 1-1/4 x 16 Ga.			
76	812 00 00-01	Ring, E			
77	532 12 35-83	Key, Square			

NOTE: All component dimensions given in U.S. inches
1 inch = 25.4 mm

REPAIR PARTS

TRACTOR- -MODEL NO. 14592RB (BA14592RBD), PRODUCT NO. 964 77 25-02
STEERING ASSEMBLY

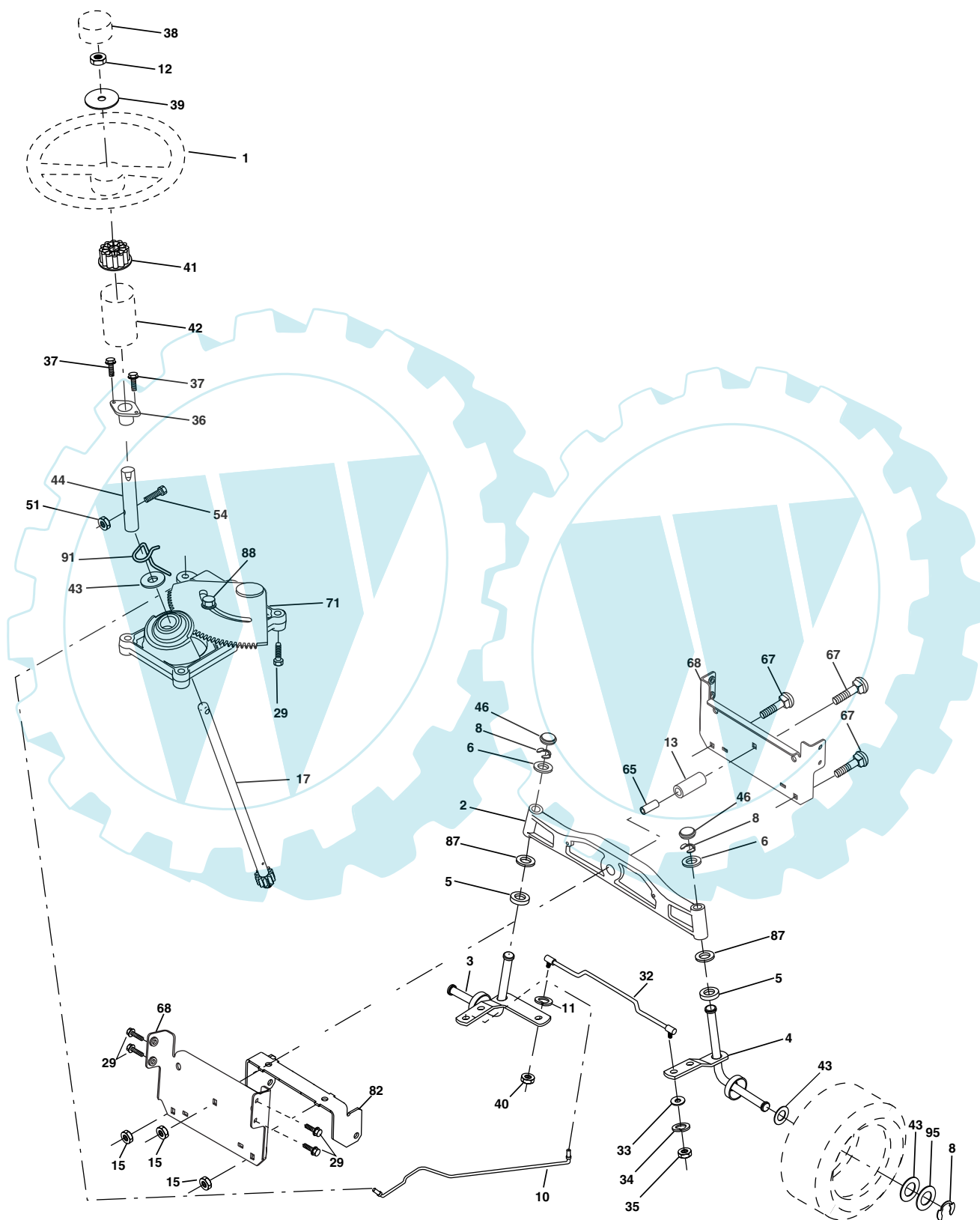

steering_pl.lt_29

REPAIR PARTS

TRACTOR- -MODEL NO. 14592RB (BA14592RBD), PRODUCT NO. 964 77 25-02
STEERING ASSEMBLY

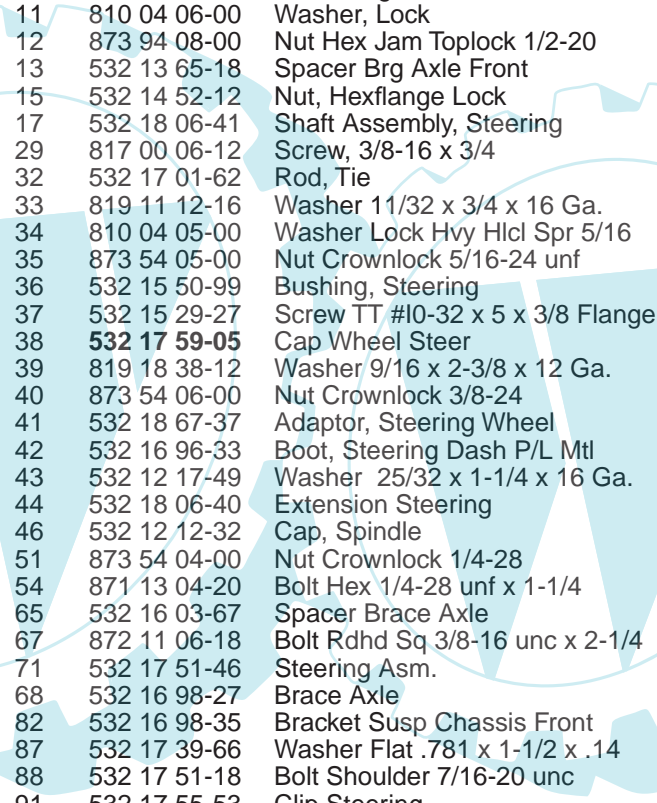

KEY NO.	PART NO.	DESCRIPTION
1	532 17 59-04	Steering Wheel
2	532 18 47-06	Cast Iron Axle Assembly
3	532 16 98-40	Spindle Assembly, L.H.
4	532 16 98-39	Spindle Assembly, R.H.
5	532 12 49-31	Bearing, Race, Thrust, Hardened
6	532 12 17-48	Washer 25/32 x 1-5/8 x 16 Ga.
8	812 00 00-29	Ring, Klip
10	532 17 51-21	Link, Drag
11	810 04 06-00	Washer, Lock
12	873 94 08-00	Nut Hex Jam Toplock 1/2-20
13	532 13 65-18	Spacer Brg Axle Front
15	532 14 52-12	Nut, Hexflange Lock
17	532 18 06-41	Shaft Assembly, Steering
29	817 00 06-12	Screw, 3/8-16 x 3/4
32	532 17 01-62	Rod, Tie
33	819 11 12-16	Washer 11/32 x 3/4 x 16 Ga.
34	810 04 05-00	Washer Lock Hvy Hlcl Spr 5/16
35	873 54 05-00	Nut Crownlock 5/16-24 unf
36	532 15 50-99	Bushing, Steering
37	532 15 29-27	Screw TT #10-32 x 5 x 3/8 Flange
38	532 17 59-05	Cap Wheel Steer
39	819 18 38-12	Washer 9/16 x 2-3/8 x 12 Ga.
40	873 54 06-00	Nut Crownlock 3/8-24
41	532 18 67-37	Adaptor, Steering Wheel
42	532 16 96-33	Boot, Steering Dash P/L Mtl
43	532 12 17-49	Washer 25/32 x 1-1/4 x 16 Ga.
44	532 18 06-40	Extension Steering
46	532 12 12-32	Cap, Spindle
51	873 54 04-00	Nut Crownlock 1/4-28
54	871 13 04-20	Bolt Hex 1/4-28 unf x 1-1/4
65	532 16 03-67	Spacer Brace Axle
67	872 11 06-18	Bolt Rdhd Sq 3/8-16 unc x 2-1/4
71	532 17 51-46	Steering Asm.
68	532 16 98-27	Brace Axle
82	532 16 98-35	Bracket Susp Chassis Front
87	532 17 39-66	Washer Flat .781 x 1-1/2 x .14
88	532 17 51-18	Bolt Shoulder 7/16-20 unc
91	532 17 55-53	Clip Steering
95	532 18 89-67	Washer Hardened

NOTE: All component dimensions given in U.S. inches.
1 inch = 25.4 mm.

REPAIR PARTS

TRACTOR- -MODEL NO. 14592RB (BA14592RBD), PRODUCT NO. 964 77 25-02
SEAT ASSEMBLY

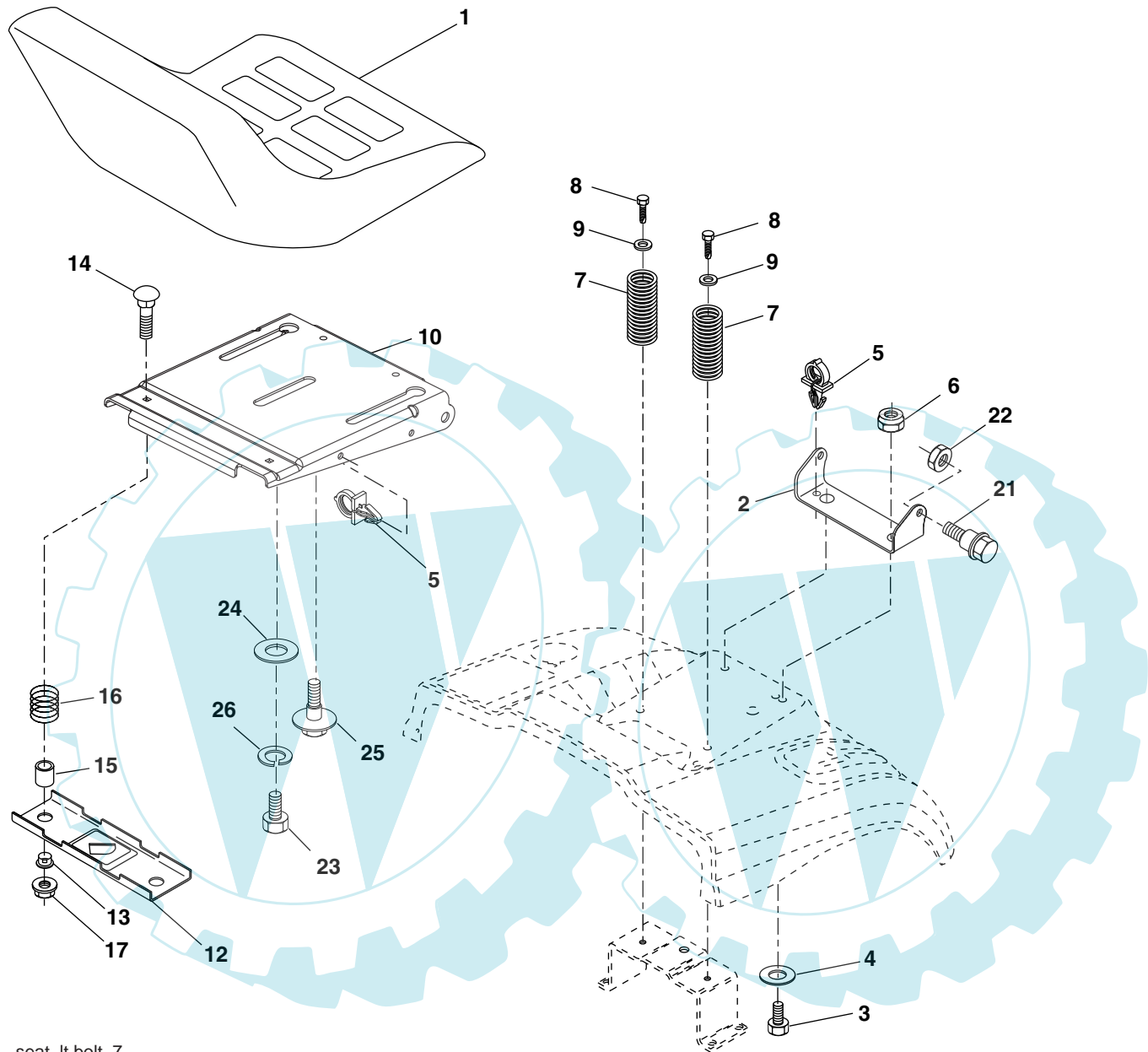

seat_lt.bolt_7

KEY NO.	PART NO.	DESCRIPTION	KEY NO.	PART NO.	DESCRIPTION
1	532 18 87-04	Seat	14	872 05 04-12	Bolt Rdhd Sht Nk 1/4-20 x 1-1/2
2	532 18 01-66	Bracket Pnt Pivot Seat (blk)	15	532 13 43-00	Spacer Split
3	871 11 06-16	Bolt Fin Hex 3/8-16 unc x 1	16	532 12 12-50	Spring Cprsn Plate SW 1.310 Ga.
4	819 13 16-10	Washer Flat 13/32 x 1 x 10 Ga.	17	532 12 39-76	Nut Lock 1/4 Lge Flg Gr. 5 Zinc
5	532 14 50-06	Clip Push In Hinged	21	532 17 18-52	Bolt Shoulder 5/16-18 unc-2A
6	873 80 06-00	Nut Lock Hex 3/8-16 unc	22	873 80 05-00	Nut Hex Lock w/Ins 5/16-18
7	532 12 41-81	Spring Seat Cprsn 2 250 Blk Zi	23	871 11 08-14	Bolt Hex Black
8	817 00 06-16	Screw 3/8-16 x 1-1/2	24	819 17 19-12	Washer 17/32 x 1-3/16 x 12 Ga.
9	819 13 16-14	Washer 13/32 x 1 x 14 Ga.	25	532 12 70-18	Bolt Shoulder 5/16-18 x 62
10	532 18 01-86	Pan Pnt Seat (blk)	26	810 04 08-00	Washer Lock Hvy Hlcl Spr 1/2
12	532 12 12-46	Bracket Pnt Mounting Switch			
13	532 12 12-48	Bushing Snap Blk Nyl 50 Id			

NOTE: All component dimensions given in U.S. inches.
1 inch = 25.4 mm

REPAIR PARTS

TRACTOR- -MODEL NO. 14592RB (BA14592RBD), PRODUCT NO. 964 77 25-02
DECALS

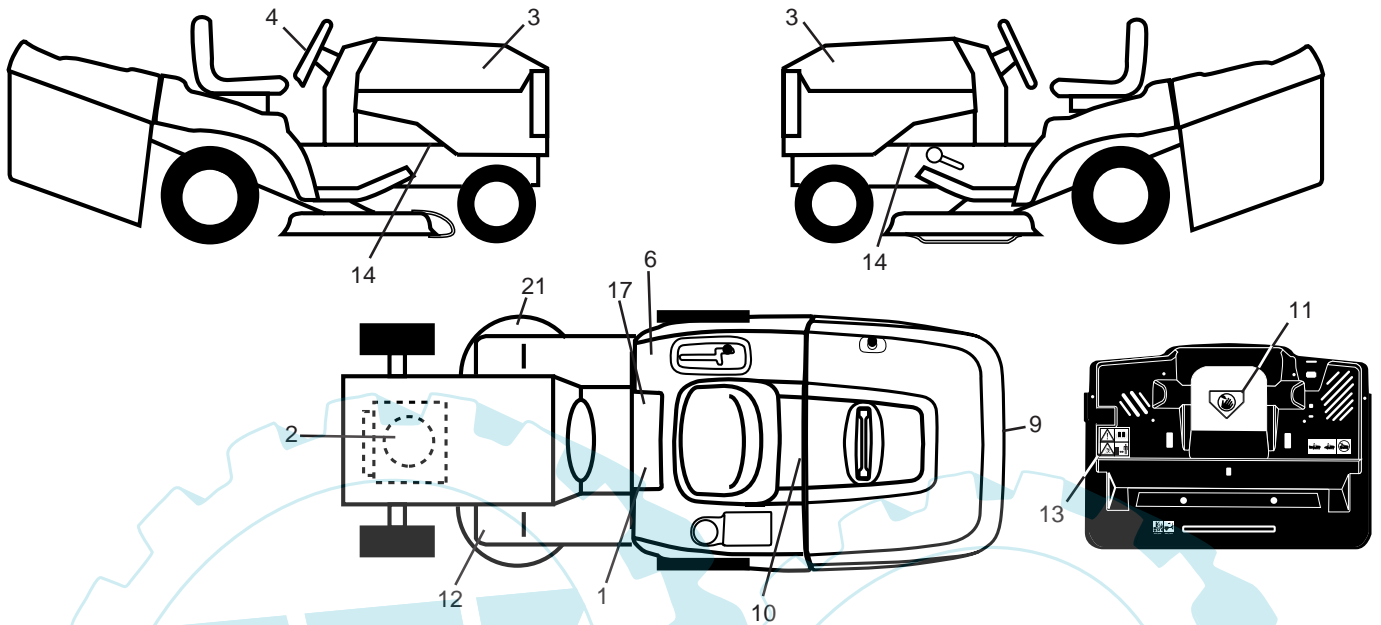

KEY NO.	PART NO.	DESCRIPTION
1	532 14 54-98	Decal Read Owner's Manual Sym
2	532 18 47-67	Decal Hp Engine
3	532 18 96-91	Decal Hood
4	532 18 96-97	Decal Steering
6	532 18 04-32	Decal Fender 100 OB/CE
9	532 18 95-73	Decal Fender
10	532 14 50-05	Decal Bat Dan/Poi P/L Sym Wpn
11	532 18 21-66	Decal Mower Cut Finger Symbol
12	532 15 97-37	Decal Brake/Clutch Symbol Lt
13	532 18 04-35	Decal Warn Back Plate CRD

KEY NO.	PART NO.	DESCRIPTION
14	532 15 97-36	Decal Chassis Hot Muffler
17	532 14 08-37	Decal Saddle Brake Parking
21	532 16 62-86	Decal Hex Belt Sch 92 CRD
—	532 18 10-90	Pad Footrest RH/
—	532 13 83-11	Decal Lift Handle
—	532 18 26-21	Decal Bagger Frame
—	532 18 10-91	Pad Footrest LH
—	532 18 52-30	Manual Operator's (Euro)
—	532 18 52-32	Manual Operator's (Scand)
—	532 18 52-35	Manual Operator's E-Block
—	532 18 94-01	Manual Parts

WHEELS & TIRES

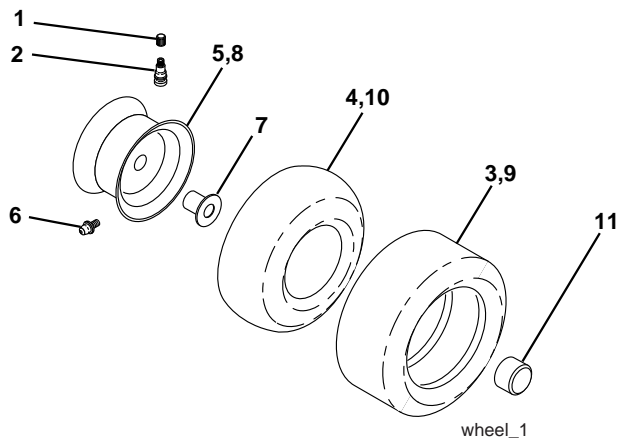

KEY NO.	PART NO.	DESCRIPTION
1	532 05 91-92	Cap Value Tire
2	532 06 51-39	Stem Value
3	532 10 62-22	Tire F Ts 15 x 6 0 - 6 Service
4	532 05 99-04	Tube Inner Front #35060
5	532 18 33-37	Rim Asm 6" front Service
6	532 12 49-57	Fitting Grease
7	532 12 49-59	Bearing Flange
8	532 18 33-38	Rim Asm 8" rear Service
9	532 10 62-68	Tire R Ts 18 x 9.5-8 Service
10	532 12 49-26	Tube Rear 9 5 x 8 Service
11	532 17 50-39	Cap Axle Blk 1 50 x 1 00
--	532 14 43-34	Sealant, Tire (10 oz. tube)

NOTE: All component dimensions given in U.S. inches
1 inch = 25.4 mm

REPAIR PARTS

TRACTOR- -MODEL NO. 14592RB (BA14592RBD), PRODUCT NO. 964 77 25-02
ENGINE

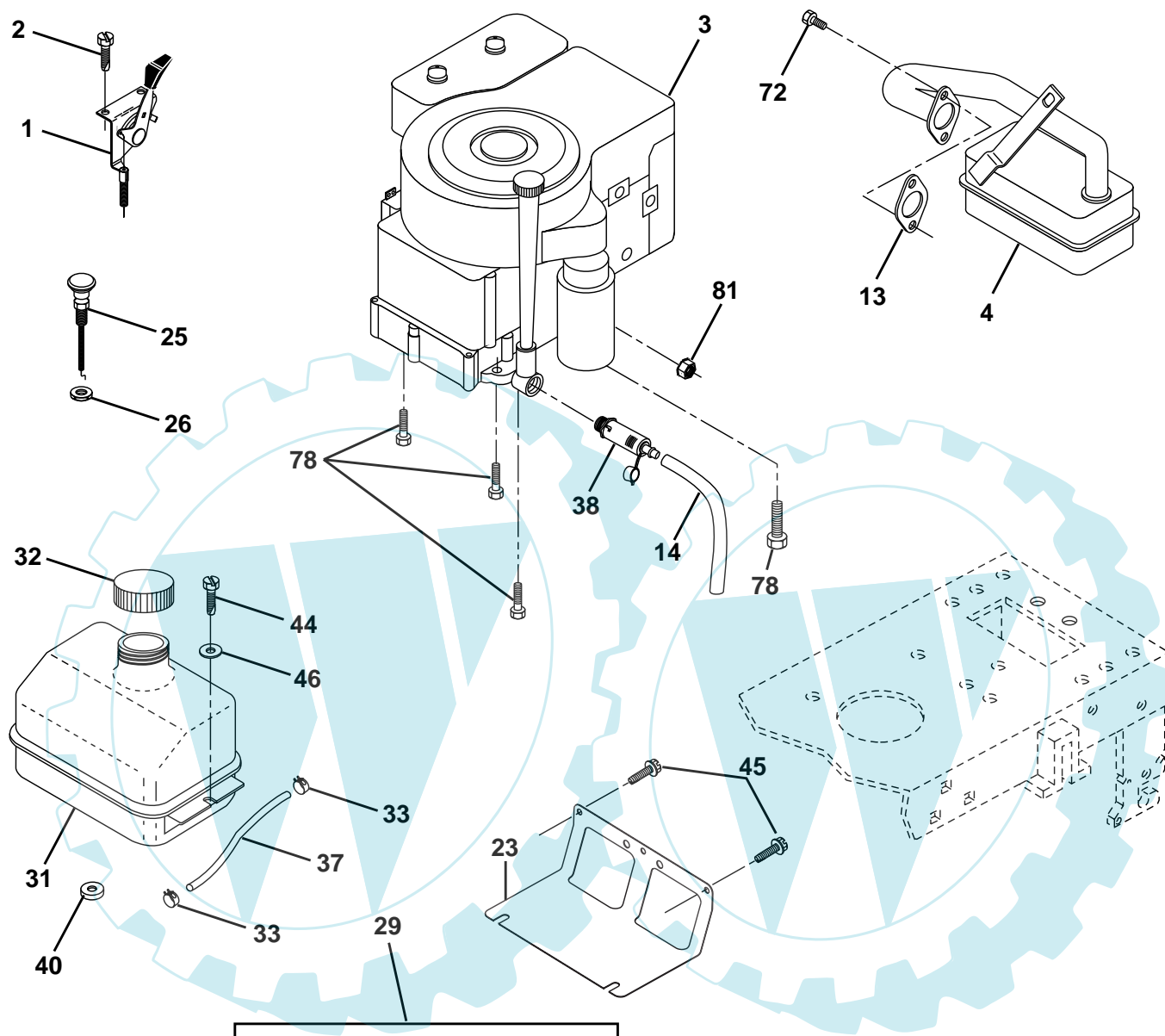

OPTIONAL EQUIPMENT
Spark Arrester

engine-bs.1cyl_37

REPAIR PARTS

TRACTOR- -MODEL NO. 14592RB (BA14592RBD), PRODUCT NO. 964 77 25-02
ENGINE

KEY NO.	PART NO.	DESCRIPTION
1	532 17 05-51	Control Throt
2	817 72 04-08	Screw Hex Thd Cut 1/4-20 x 1/2
3	-----	Engine B&S Model 21A807 (Order Parts from Engine Manufacturer)
4	532 13 73-52	Muffler Exhaust B&S Lt
13	532 16 52-91	Gasket 1 313 Id Tin Plated
14	532 14 84-56	Tube Drain Oil Easy
23	532 16 98-37	Shield Browning/Debris Guard
25	532 18 09-45	Control Choke
26	873 92 06-00	Nut Keps 3/8-24 unf
29	532 13 71-80	Arrestor Spark
31	532 18 49-00	Tank Fuel 1.25
32	532 14 05-27	Cap Asm Fule Top Vent N/Lany
33	532 12 34-87	Clamp Hose Blk
37	532 13 70-40	Line Fuel 20"
38	532 18 16-54	Plug Drain Oil Easy
44	817 67 04-12	Screw Hexwsh Thdrol 3/8-16 x 3/4
45	817 00 06-12	Screw 3/8-16 x 3/4
46	819 09 14-16	Washer 9/32 x 7/8 x 16 Ga.
72	532 18 39-06	Screw Socket Head 5/16-18 x 1
78	817 06 06-20	Screw 3/8-16x1-1/4
81	873 51 04-00	Nut Keps Hex 1/4-20 unc

NOTE: All component dimensions given in U.S. inches
1 inch = 25.4 mm

REPAIR PARTS

TRACTOR- -MODEL NO. 14592RB (BA14592RBD), PRODUCT NO. 964 77 25-02
MOWER LIFT

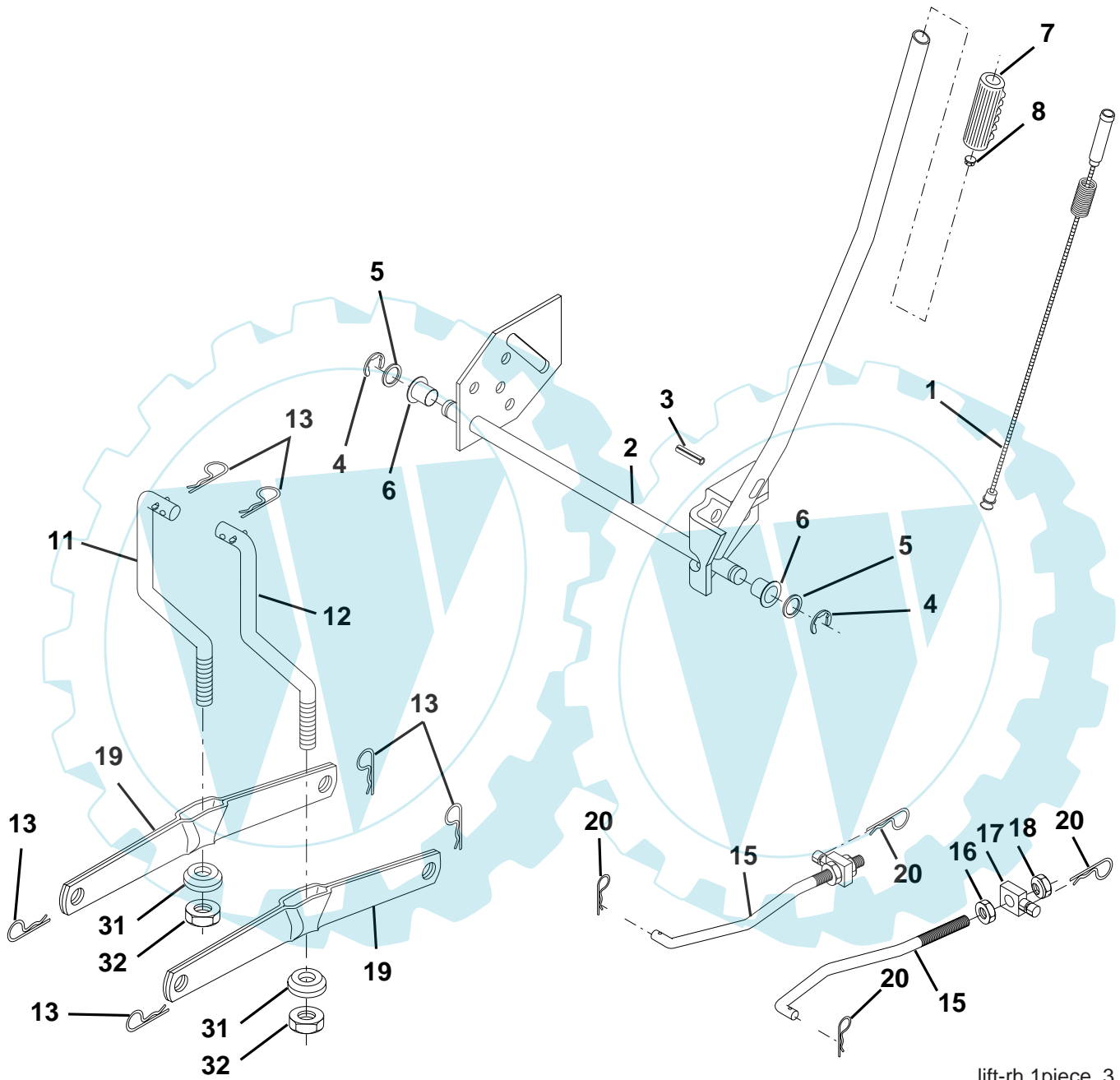

lift-rh.1piece_3

REPAIR PARTS

TRACTOR- -MODEL NO. 14592RB (BA14592RBD), PRODUCT NO. 964 77 25-02
MOWER LIFT

KEY NO.	PART NO.	DESCRIPTION
1	532 15 94-61	Wire Asm Inner Spring W/Plunger
2	532 15 94-76	Shaft Asm. Lift
3	532 17 89-81	Pin Groove
4	812 00 00-02	E Ring #5133-62
5	819 21 16-21	Washer 21/32 x 1 x 21 Ga.
6	532 12 01-83	Bearing Nylon
7	532 10 94-13	Grip Handle Bicycle
8	532 12 45-26	Button Plunger Black
11	532 16 58-29	Link Asm Lift L.H.
12	532 16 58-31	Link Asm Lift R.H.
13	532 12 46-70	Retainer Spring
15	532 17 32-88	Link Front
16	873 35 08-00	Nut Jam Hex 1/2-13 unc
17	532 17 56-89	Trunnion Blk Zinc
18	873 80 08-00	Nut Lock w/Wsh 1/2-13 unc
19	532 13 98-68	Arm Suspension Mower
20	532 16 35-52	Retainer Spring
31	532 16 98-65	Bearing, Pvt. Lift.
32	873 54 06-00	Nut Crownlock 3/8-24

NOTE: All component dimensions given in U.S. inches
1 inch = 25.4 mm

REPAIR PARTS

TRACTOR- -MODEL NO. 14592RB (BA14592RBD), PRODUCT NO. 964 77 25-02
MOWER



36(92cm)_deck-elect.(CRD)_1
36 GW med/wide/std

REPAIR PARTS

TRACTOR- -MODEL NO. 14592RB (BA14592RBD), PRODUCT NO. 964 77 25-02
MOWER

KEY NO.	PART NO.	DESCRIPTION	KEY NO.	PART NO.	DESCRIPTION
1	532 16 55-52	Housing Asm. Mower	40	873 68 06-00	Nut Crownlock 3/8-16 unc
2	872 14 05-06	Bolt Rdhd Sqnk 5/16-18 unc x 3/4	41	873 90 06-00	Nut Lock Flg 3/8-16 unc
3	532 16 55-69	Bracket Asm. S-Bar Chass	44	532 17 55-38	Cover Mandrel Lh
4	532 16 55-58	Bracket Bar Sway Deck	45	532 17 55-39	Cover Mandrel Rh
5	532 12 46-70	Retainer Spring	46	532 13 77-29	Screw Thd Roll 1/4-20 x 5/8
6	532 16 55-57	Bar Sway	55	532 16 54-45	Arm Idler
8	532 18 17-12	Bolt 3/8-24 x 1.25 Gr. 8 Patched	56	532 16 57-23	Spacer Retainer PM Mower
9	810 03 06-00	Washer Lock Hvy 3/8 Unplated	61	532 16 59-45	Spring Tension Belt
11	532 18 63-85	Blade 3-1 Lh	67	532 10 69-32	Knob Rd 3/8-16 Plstc Thds Blk
13	532 13 76-45	Shaft Asm. W/Lower Bearing	68	532 18 02-17	Hex-Belt 92 Mower
14	532 12 87-74	Housing Mandrel Vented (Machd)	69	532 16 54-82	Shaft Asm W/Lwr Brg Rh Thd CRD
15	532 11 04-85	Bearing Ball Mandrel	84	532 15 60-85	Keeper Belt Idler
16	532 18 63-86	Blade 3-1 Rh	116	532 18 42-19	Bolt Shoulder
17	872 14 06-10	Bolt Carriage 3/8-16 x 1-1/4	117	532 13 39-57	Wheel Gage Donut Wide
18	872 11 06-06	Bolt Rdhd Sqnk 3/8-16 x 3/4	118	873 93 06-00	Nut Centerlock 3/8-16 unc
19	532 13 28-27	Bolt Shoulder 5/16-18 Thd Form	119	819 12 14-14	Washer 3/8 x 7/8 x 14 Ga.
20	532 18 17-13	Bolt 3/8-24 x 1.25 Gr. 8 Ptch Lhthd	124	872 11 06-12	Bolt Carr Sh 3/8-16 x 1-1/2 Gr. 5
21	873 68 05-00	Nut Crown Lock 5/16-18	130	872 11 05-06	Bolt Rdhdsqnk 5/16-18 unc x 3/4
22	532 16 52-43	Bracket Idler Sprt RR	131	532 16 56-61	Chute Bagger CRD
23	532 16 54-46	Bracket Idler Sprt RF	152	532 17 60-74	Cable Clutch CRD Service
24	532 16 52-42	Bracket Suspension LF	158	817 72 04-08	Screw Hex Thdcut 1/4-20 x 5/8
25	532 16 52-44	Bracket Suspension RF	161	532 18 63-87	Blade Cross Lh 92
26	532 16 52-37	Brace Support Susp Frt CRD	162	532 18 08-78	Adpater Blade Cross
27	532 16 55-68	Bracket Asm. Susp RR	163	532 18 63-88	Blade Cross Rh 92
28	532 16 55-67	Bracket Asm. Susp LR	185	532 18 82-34	Head Asm. Cable Clutch
30	532 17 39-84	Screw Thd Rolling Washer Head	--	532 18 18-57	Mandrel Asm Service
31	532 18 76-90	Washer Spacer	--	532 18 18-58	Mandrel Asm CRD Lh Threads
32	532 15 35-31	Mandrel Pulleys 36 & 46	--	532 18 85-23	SVC
33	532 17 83-42	Nut Flg Top Lock			Replacement Mower Complete- -
34	532 16 52-39	Bracket Gauge Wheel Lf			(Std. deck Order separately gauge
35	532 16 52-38	Bracket Gauge Wheel Rf			wheel components Key Nos. 116-
36	532 14 67-63	Pulley Idler V-Groove Dim 4.25			119)
37	819 13 13-16	Washer 11/32 x 13/16 x 16 Ga.			

NOTE: All component dimensions given in U.S. inches
1 inch = 25.4 mm

REPAIR PARTS

TRACTOR- -MODEL NO. 14592RB (BA14592RBD), PRODUCT NO. 964 77 25-02
BAGGER

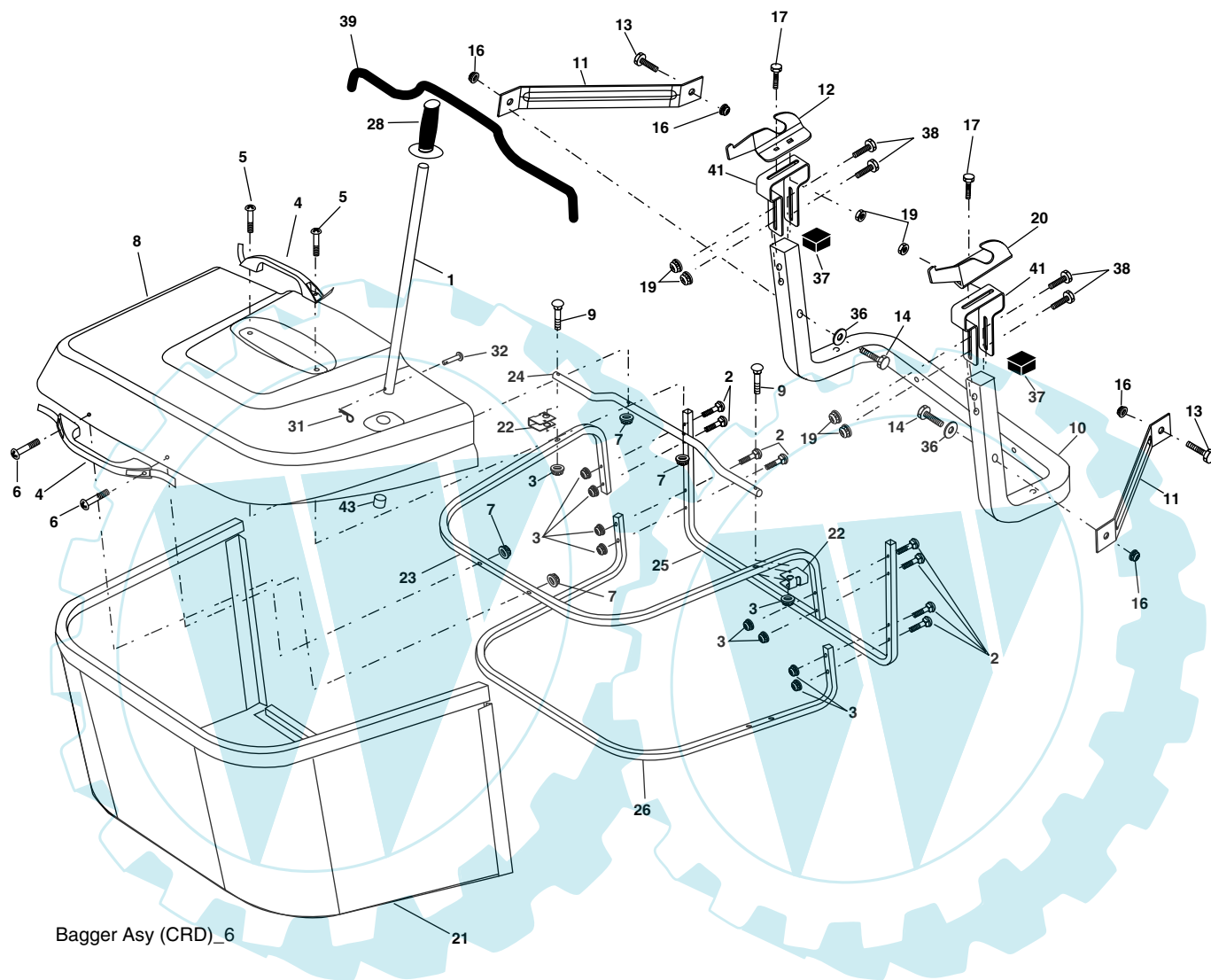

REPAIR PARTS

TRACTOR- -MODEL NO. 14592RB (BA14592RBD), PRODUCT NO. 964 77 25-02
BAGGER

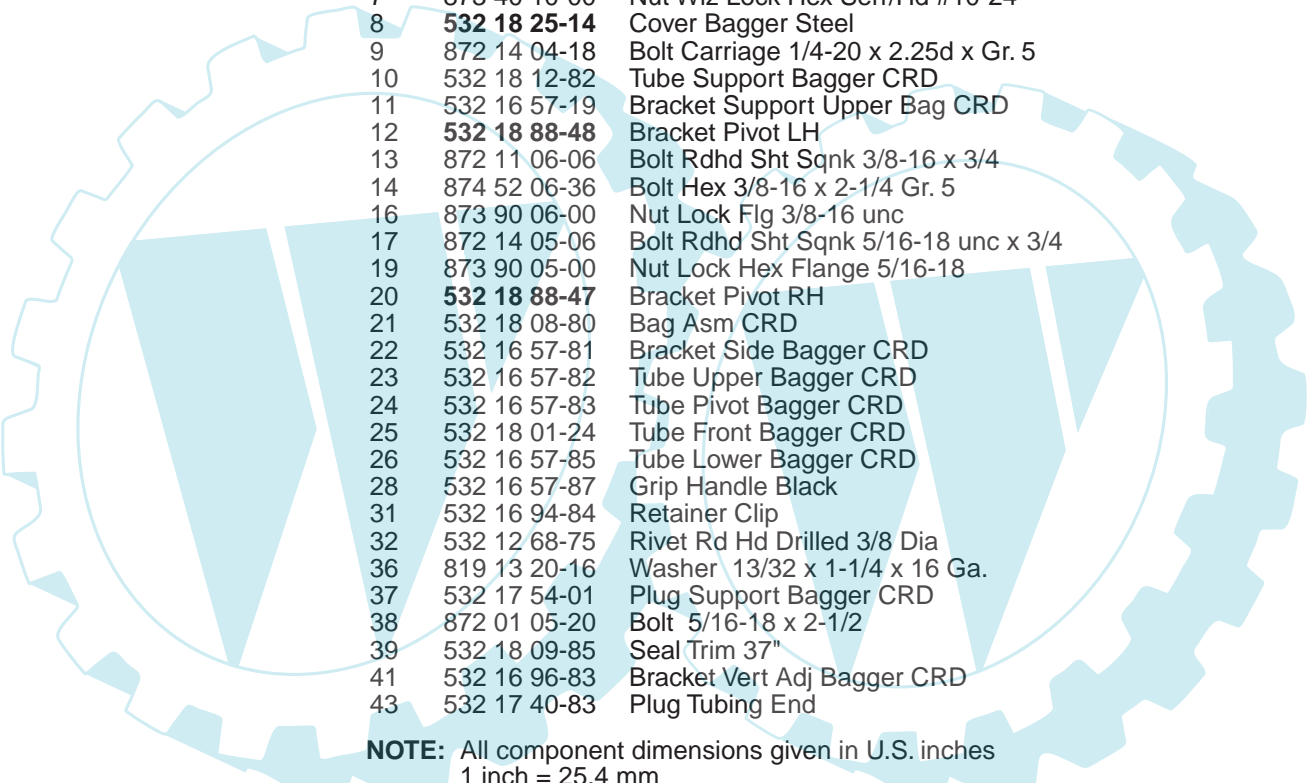

KEY NO.	PART NO.	DESCRIPTION
1	532 16 52-49	Tube Handle Bagger CRD
2	872 14 04-16	Bolt Carriage 1/4-20 x 2.0 Gr.5
3	532 12 39-76	Nut Lock 1/4 Lge Flg Gr. 5 Zinc
4	532 16 99-16	Handle Bagger w/Lvrs Gr. 5 Zinc
5	874 98 10-24	Screw Pan Head #10-24 x 1.50 Blk
6	874 98 10-32	Screw Pan Hd
7	873 40 10-00	Nut Wiz Lock Hex Serr/Hd #10-24
8	532 18 25-14	Cover Bagger Steel
9	872 14 04-18	Bolt Carriage 1/4-20 x 2.25d x Gr. 5
10	532 18 12-82	Tube Support Bagger CRD
11	532 16 57-19	Bracket Support Upper Bag CRD
12	532 18 88-48	Bracket Pivot LH
13	872 11 06-06	Bolt Rdhd Sht Sqnk 3/8-16 x 3/4
14	874 52 06-36	Bolt Hex 3/8-16 x 2-1/4 Gr. 5
16	873 90 06-00	Nut Lock Flg 3/8-16 unc
17	872 14 05-06	Bolt Rdhd Sht Sqnk 5/16-18 unc x 3/4
19	873 90 05-00	Nut Lock Hex Flange 5/16-18
20	532 18 88-47	Bracket Pivot RH
21	532 18 08-80	Bag Asm CRD
22	532 16 57-81	Bracket Side Bagger CRD
23	532 16 57-82	Tube Upper Bagger CRD
24	532 16 57-83	Tube Pivot Bagger CRD
25	532 18 01-24	Tube Front Bagger CRD
26	532 16 57-85	Tube Lower Bagger CRD
28	532 16 57-87	Grip Handle Black
31	532 16 94-84	Retainer Clip
32	532 12 68-75	Rivet Rd Hd Drilled 3/8 Dia
36	819 13 20-16	Washer 13/32 x 1-1/4 x 16 Ga.
37	532 17 54-01	Plug Support Bagger CRD
38	872 01 05-20	Bolt 5/16-18 x 2-1/2
39	532 18 09-85	Seal Trim 37"
41	532 16 96-83	Bracket Vert Adj Bagger CRD
43	532 17 40-83	Plug Tubing End

NOTE: All component dimensions given in U.S. inches
1 inch = 25.4 mm



SERVICE POLICY WARRANTY

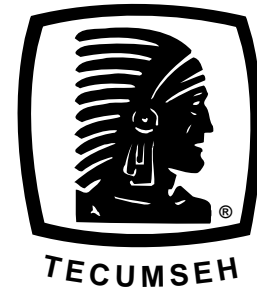

Issued January 1980
Revised January 1991

LIMITED WARRANTIES FOR NEW PEERLESS GEAR POWER TRAIN COMPONENTS

A. Products Warranted

Peerless Gear and Machine Division of Tecumseh Products Company ("Tecumseh"), subject to the limitations contained below, will, at its option, repair or replace, without charge for parts or labor only, any part of a new Power Train Component (which as used herein means and includes the transaxle, gear box, transmission, differential and right angle drives, and any part of the Power Train Component), EXCEPT any new Power Train Component incorporated in equipment used for commercial or rental purposes, which is found upon examination by any Tecumseh Authorized Service Outlet or by Tecumseh's factory in Grafton, Wisconsin, to be DEFECTIVE IN MATERIAL AND/OR WORKMANSHIP if received by Tecumseh or a Tecumseh Authorized Service Outlet for such examination within TWO YEARS from the date of sale to the original consumer purchaser of Peerless Series 820, 900, 910, 915, 920, 930 transaxles and Series 1100 angle drive and ONE YEAR for all other Peerless products. New Power Train Components incorporated in equipment used for commercial purposes are warranted in the same manner and to the same extent EXCEPT such Power Train Components are warranted for NINETY (90) DAYS ONLY, and must be received by Tecumseh or by a Tecumseh Authorized Service Outlet for such examination within 90 days from the date of sale to the original purchaser. New Power Train Components incorporated in equipment used for rental purposes are warranted in the same manner and to the same extent EXCEPT such Power Train Components are warranted for THIRTY (30) DAYS ONLY, and must be received by Tecumseh or a Tecumseh Authorized Service Outlet within 30 days from the date of sale to the original purchaser.

B. Products And Items Not Warranted

1. Alterations or Modifications of Power Train Components.
2. Accidents, Normal Maintenance, Failure to follow the Original Equipment Manufacturer's Manual.

This warranty covers only parts of new Power Train Components which are found upon examination to be defective in material or workmanship as delivered to the original purchaser. This warranty does not cover defects caused by depreciation or damage caused by normal wear, accidents, improper maintenance, improper use or abuse of the product, failure to follow the instructions contained in an Instruction Manual for the operation of the Power Train Component and parts. The cost of normal maintenance and replacement of service items which are not defective shall be paid for by the original purchaser.

C. Securing Warranty Service

Warranty service can be arranged for by contacting either a Tecumseh Authorized Service Outlet (any Tecumseh Registered Service Dealer, Tecumseh Authorized Service Distributor, or Tecumseh Central Warehouse Distributor) or by contacting Tecumseh, c/o Service Manager, Engine and Transmission Group Service Division, 900 North Street, Grafton, Wisconsin 53024. Warranty service can only be performed by a Tecumseh Authorized Service Outlet or by Tecumseh at its factory in Grafton, Wisconsin. At the time of requesting warranty service, evidence must be presented of the date of sale to the original purchaser. The purchaser shall pay any charges for making service calls and/or for transporting the product to and from the place where the inspection and/or warranty work is performed. The purchaser shall be responsible for any damage or loss incurred in connection with the transportation of Power Train Components and/or part(s) of the Power Train Components submitted for inspection and/or warranty work.

D. Limitation of Damages and Implied Warranties

The foregoing EXPRESSED WARRANTY IS IN LIEU OF ALL OTHER EXPRESS WARRANTIES. Neither Tecumseh nor any of its affiliates makes any warranties, representations or promises, written or oral, as to the quality of the Power Train Component or any of its parts, other than as set forth herein.

ANY IMPLIED WARRANTY OF MERCHANTABILITY OR FITNESS FOR A PARTICULAR PURPOSE, TO THE EXTENT THAT EITHER MAY APPLY TO ANY PART(S) OF POWER TRAIN COMPONENTS, SHALL BE LIMITED IN DURATION TO THE PERIODS OF THE EXPRESSED WARRANTIES DEFINED IN PARAGRAPH A HEREOF. IN NO EVENT WILL TECUMSEH BE LIABLE FOR ANY INCIDENTAL, CONSEQUENTIAL OR SPECIAL DAMAGES AND/OR EXPENSES. Some states do not allow limitations on how long an implied warranty lasts or the exclusion or limitation of incidental or consequential damages, so the above limitation(s) or exclusion(s) may not apply to you. This warranty gives you specific legal rights and you may also have other legal rights which vary from state to state.

E. No Dealer Warranty

Tecumseh neither assumes nor authorizes any other person, natural or corporate, to assume for Tecumseh any other obligations or liabilities in connection with or with respect to any part(s) of a Power Train Component. The seller or dealer of part(s) of a Power Train Component has no authority, whatsoever, to make any representations or promises on behalf of Tecumseh or to modify the terms or limitations of Tecumseh's warranty in any way.

LIMITED WARRANTY

The Manufacturer warrants to the original consumer purchaser that this product as manufactured is free from defects in materials and workmanship. For a period of one (1) year from date of purchase by the original consumer purchaser, we will repair or replace, at our option, without charge for parts or labor incurred in replacing parts, any part which we find to be defective due to materials or workmanship. This Warranty is subject to the following limitations and exclusions.

1. This warranty does not apply to the engine. Please contact your nearest dealer where they will send the machine to the engine manufacturer.
2. Transportation charges for the movement of any power equipment unit or attachment are the responsibility of the purchaser. Transportation charges for any parts submitted for replacement under this warranty must be paid by the purchaser unless such return is requested by your dealer.
3. Battery Warranty: On products equipped with a Battery, we will replace, without charge to you, any battery which we find to be defective in manufacture, during the first ninety (90) days of ownership. After ninety (90) days, we will exchange the Battery, charging you 1/12 of the price of a new Battery for each full month from the date of the original sale. Battery must be maintained in accordance with the instructions furnished.
4. The Warranty period for any products used for rental or commercial purposes is limited to 90 days from the date of original purchase.
5. This Warranty applies only to products which have been properly assembled, adjusted, operated, and maintained in accordance with the instructions furnished. This Warranty does not apply to any product which has been subjected to alteration, misuse, abuse, improper assembly or installation, delivery damage, or to normal wear of the product.
6. Exclusions: Excluded from this Warranty are belts, blades, blade adapters, normal wear, normal adjustments, standard hardware and normal maintenance.
7. In case of any problem within the boundaries of this warranty, contact the nearest department store, indicate the model number, serial number and the date of purchase of your machine. This warranty does not apply to accidental damages. All implicit warranties are limited to the same time frames. Or contact:

E.M. Services
54 Rue Lambrechts
92400 Courbevoie
France
Telephone: (1) 46678078
Fax: (1) 46678095

THIS WARRANTY DOES NOT APPLY TO INCIDENTAL OR CONSEQUENTIAL DAMAGES. ANY IMPLIED WARRANTIES ARE LIMITED TO THE SAME TIME PERIODS STATED HEREIN.

Electrolux Outdoor Products Service Contacts

BELGIQUE/BELGIË

Electrolux Outdoor Products
Tel: 02 363 0311, Fax: 02 363 0391

ČESKÁ REPUBLIKA

Electrolux, spol. S.r.o., oz Electrolux Outdoor Products,
Na Krecku 365 Praha 10 - Horní Mecholupy
Tel: 02/7487 0164, Info-linka: 0800/110 220
Internet: www.partner-flymo.cz E-mail: info@husqvarna.cz

DANMARK

Electrolux Outdoor Products, Flymo/Partner A/S,
Lundtoftegrdsvej 93A, DK 2800 Kgs.Lyngby
Tel: 45 87 75 77, Fax 45 93 33 08 www.flymo-partner.dk

DEUTSCHLAND

Electrolux Outdoor Products
Tel: 097 21 7640, Fax:097 21 764202

ESTONIA

Electrolux Estonia Ltd (Electrolux Eesti AS)
Tel: (372) 6650010

FRANCE

Electrolux Outdoor Products
Tel 01 46 67 8141, Fax 01 43 34 2491

FINLAND SUOMI

Electrolux Outdoor Products Finland
Tel: 00 39611, Fax: 00 39 612632

ITALIA

McCulloch Italiana s.r.l. - Via Como 72, 23868 Valmadrera
(LECCO) - ITALIA, Tel: 800 017829, Fax: 0341 581671

IRELAND

Electrolux Outdoor Products
Tel: 01 4565222, Fax: 01 4568551

MAGYARORSZÁG

Electrolux Lehel Kft
Tel: 00 36 1 251 41 47

NORGE

Electrolux Outdoor Products
Tel: 69 10 47 90

NEDERLAND

Electrolux Outdoor Products BV
Tel: 0172-468322, Fax: 0172-468219

ÖSTERREICH

HUSQVARNA Zentralwerksttte, Industriezeile 36, 4020 LINZ,
Tel: 0732 770101-60, Fax: 0732 795922

POLSKA

Electrolux Poland Sp. z.o.o. Husqvarna, 01-612 Warszawa
Myslowicka 10/2
Tel:- (22) 8332949

SLOVENIJA

HUSQVARNA-Ges.m.b.H. Nfg. KG, Industriezeile 36, 4020 LINZ,
Tel: 0732 77 01 01-0, Fax: 0732 77 01 01.40
Internet: www.husqvarna.at E-mail: office@husqvarna.co.at

SLOVENSKA

Electrolux Slovakia s.r.o., Borova Sihot 211, 033 01 Lipt. Hradok
Tel: 044 522 14 19, Fax: 044 522 14 18, www.flymo-partner.sk

SCHWEIZ/SUISSE/SUIZZERA

Electrolux Outdoor Products
Tel 062 889 93 50 / 889 94 25, Fax 062 889 93 60 / 889 94 35

SVERIGE

Electrolux Outdoor Products, Sverige
Tel: 036 û 14 67 00, Fax: 036 û 14 60 70

UNITED KINGDOM

Electrolux Outdoor Products, United Kingdom
Tel: 01325 300303, Fax: 01325 310339

McCULLOCH^{PM}

www.electrolux.com/mcculloch

Ihr Ersatzteilspezialist im Internet